

nomadic workbench
*Harmonizing Historic and Contemporary
Approaches for Furniture Design*

Front Elevation

scale 3"=1'-0"

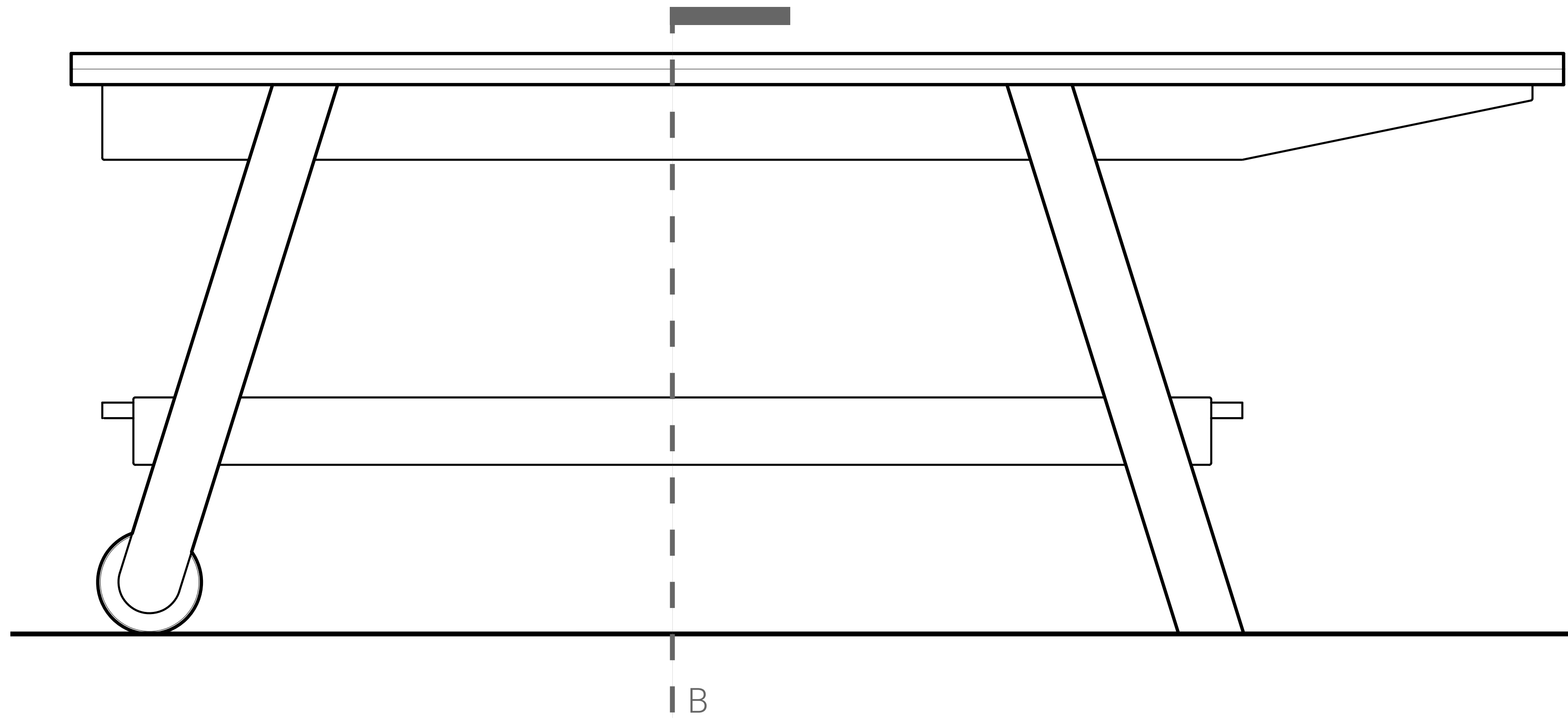

Side Elevation

scale 3"=1'-0"

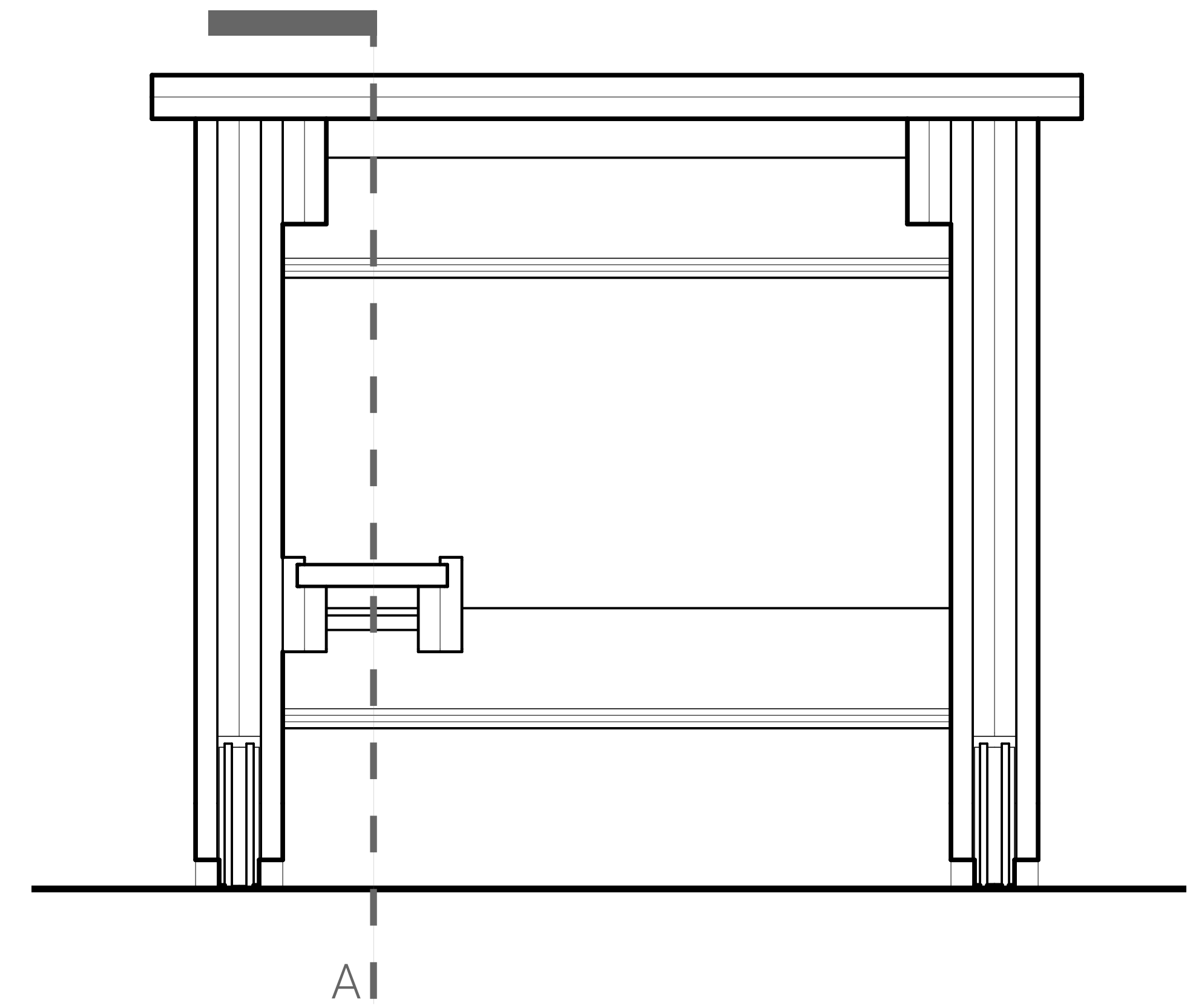

Section A

scale 3"=1'-0"

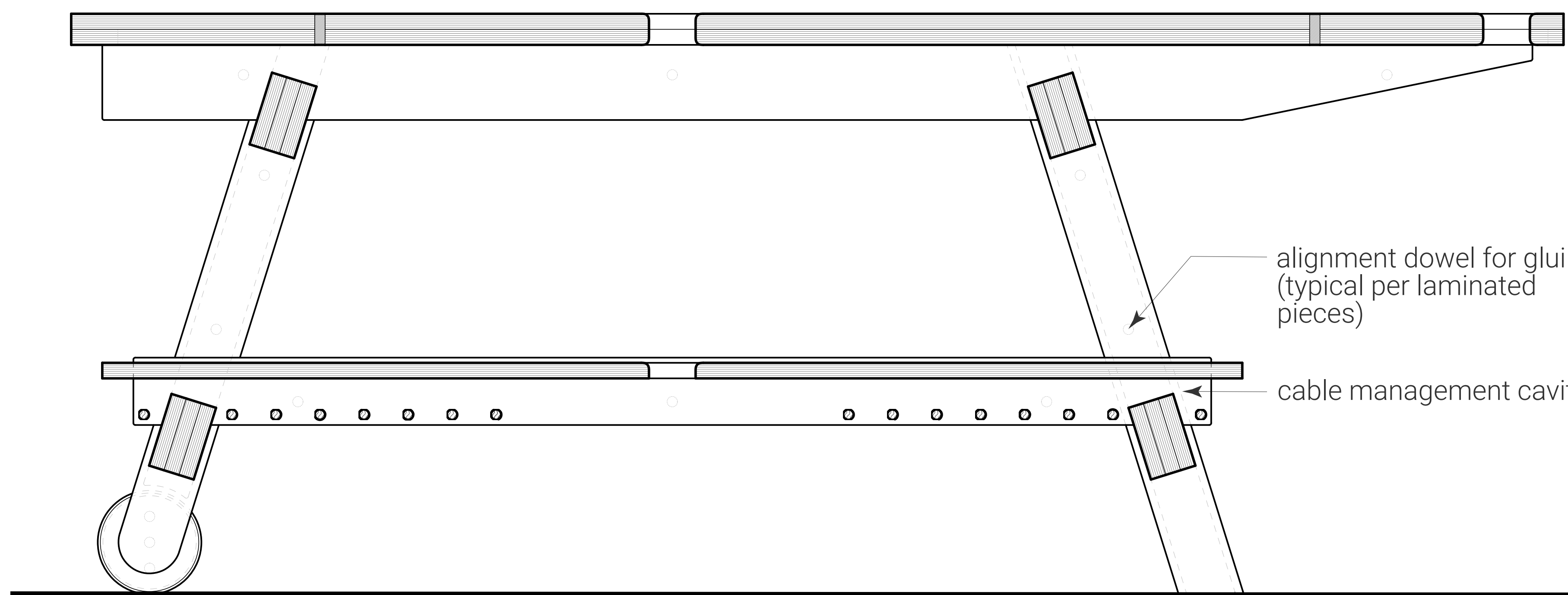

Section B

scale 3"=1'-0"

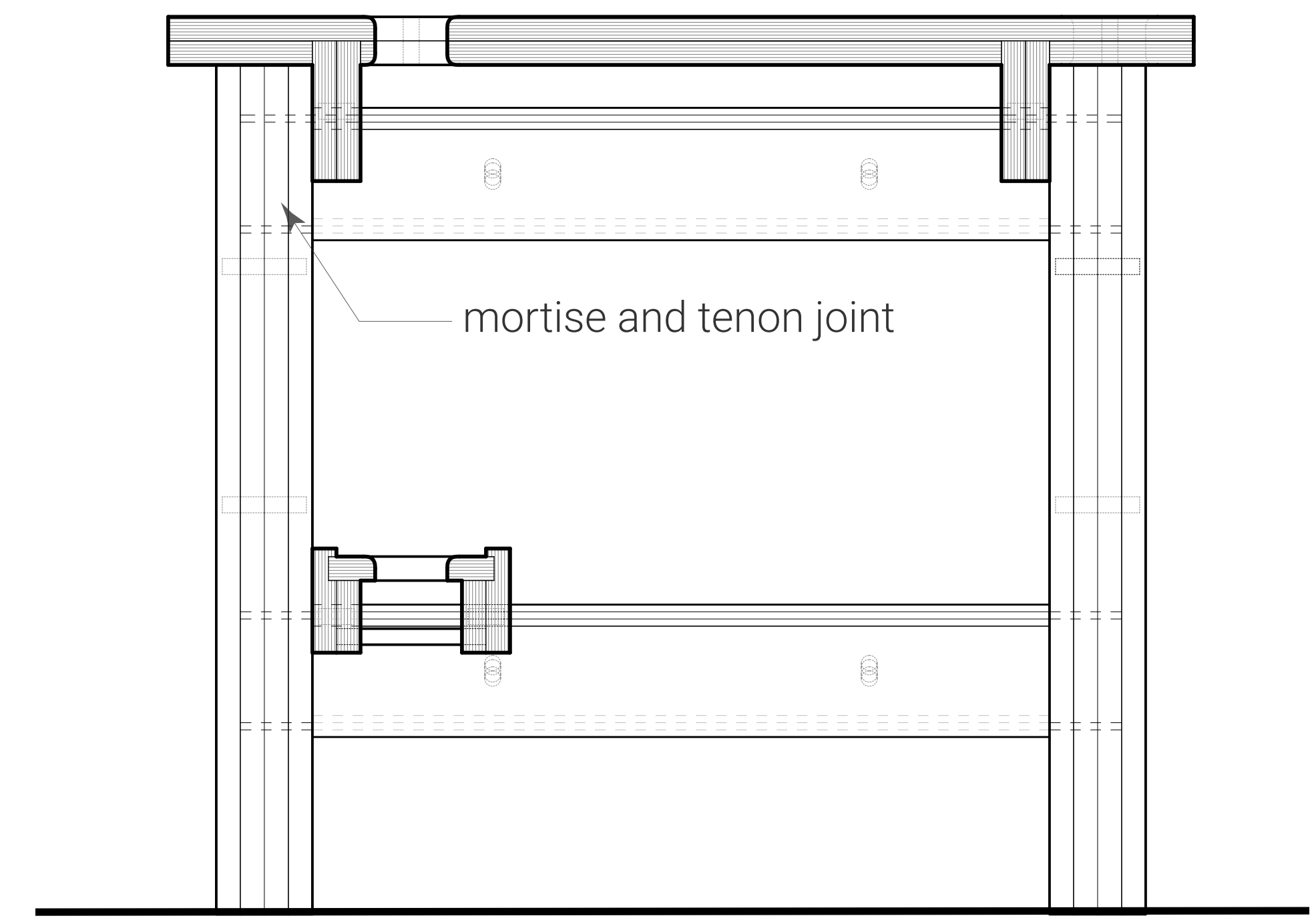

nomadic workbench

elevations and sections

workbench components

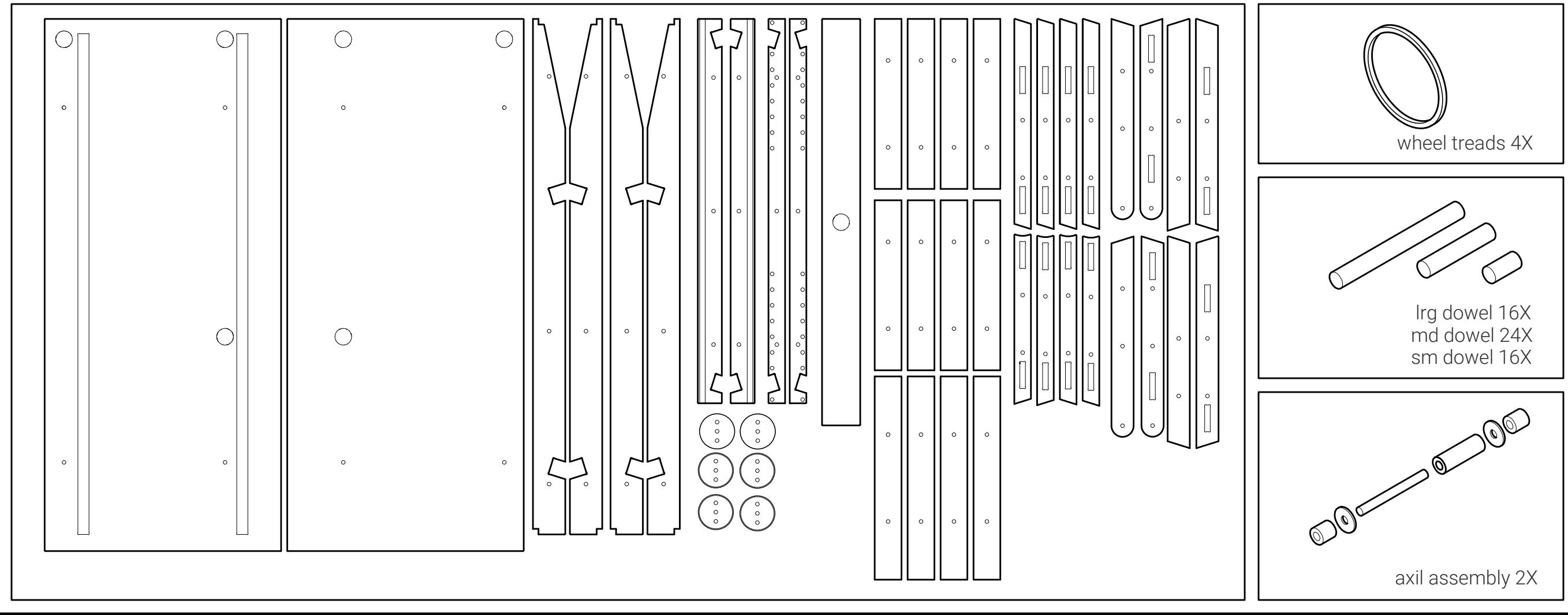

01.00: crossbar assembly 4x

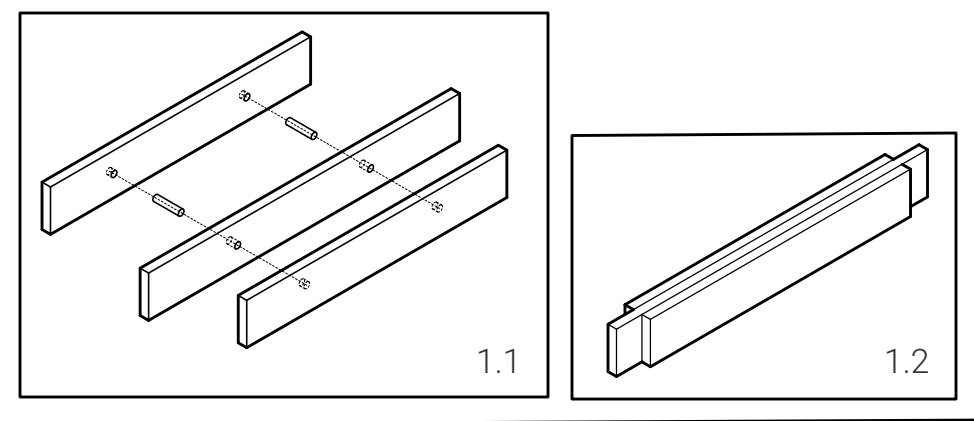

02.00 wheel assembly 2x

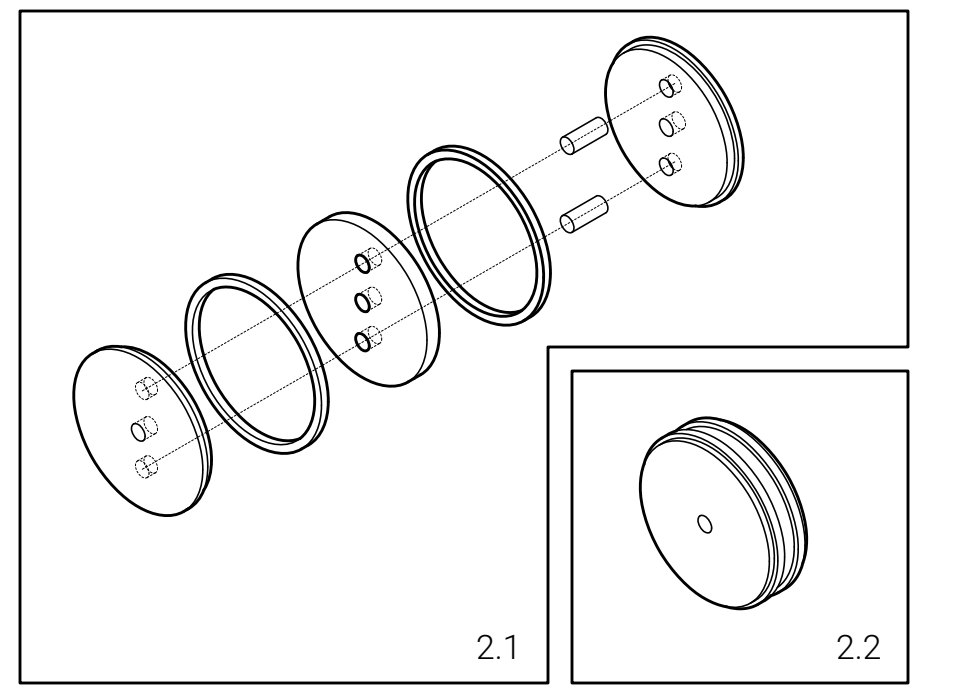

03.00: wheel leg assembly 1x

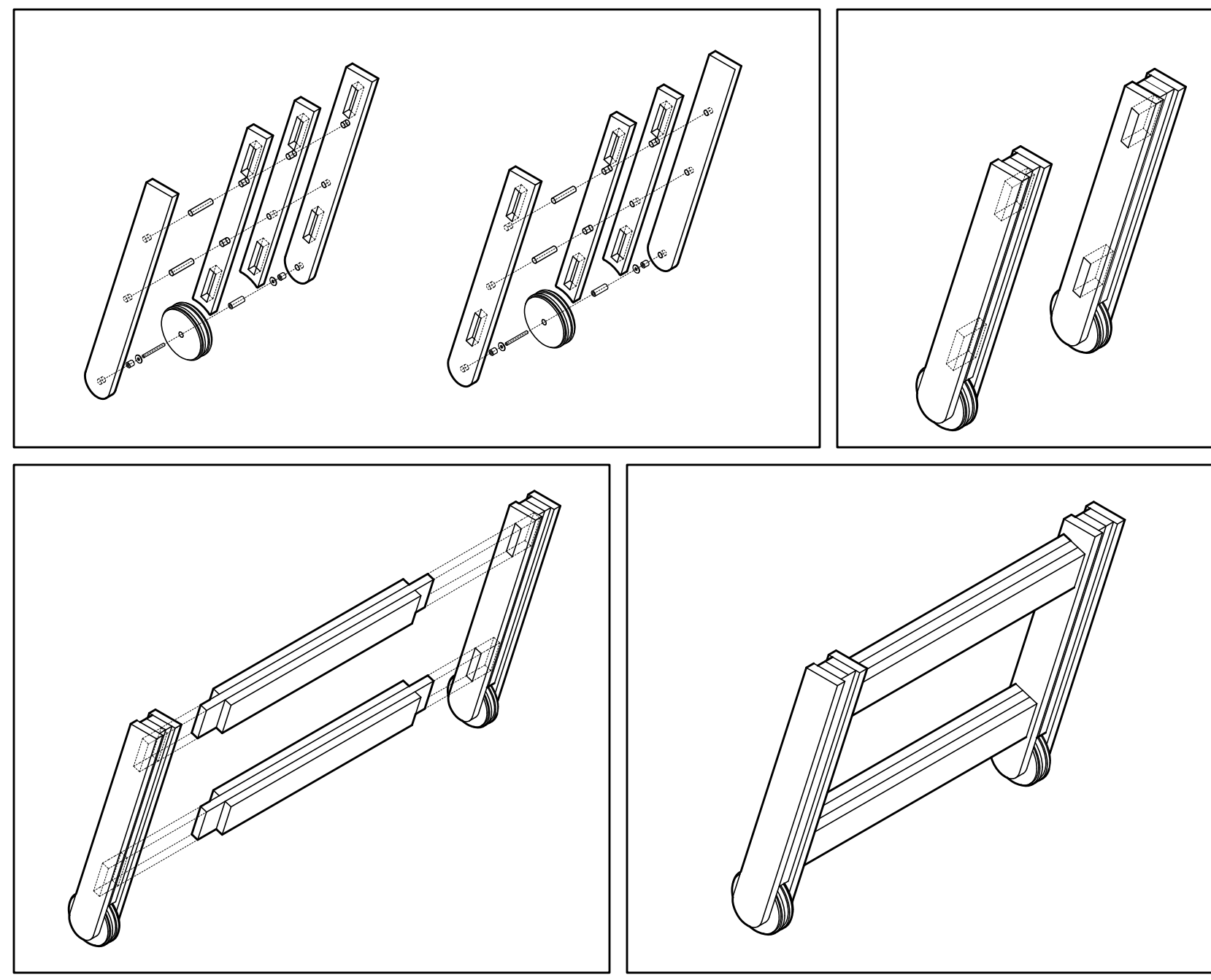

04.00: fixed leg assembly 1x

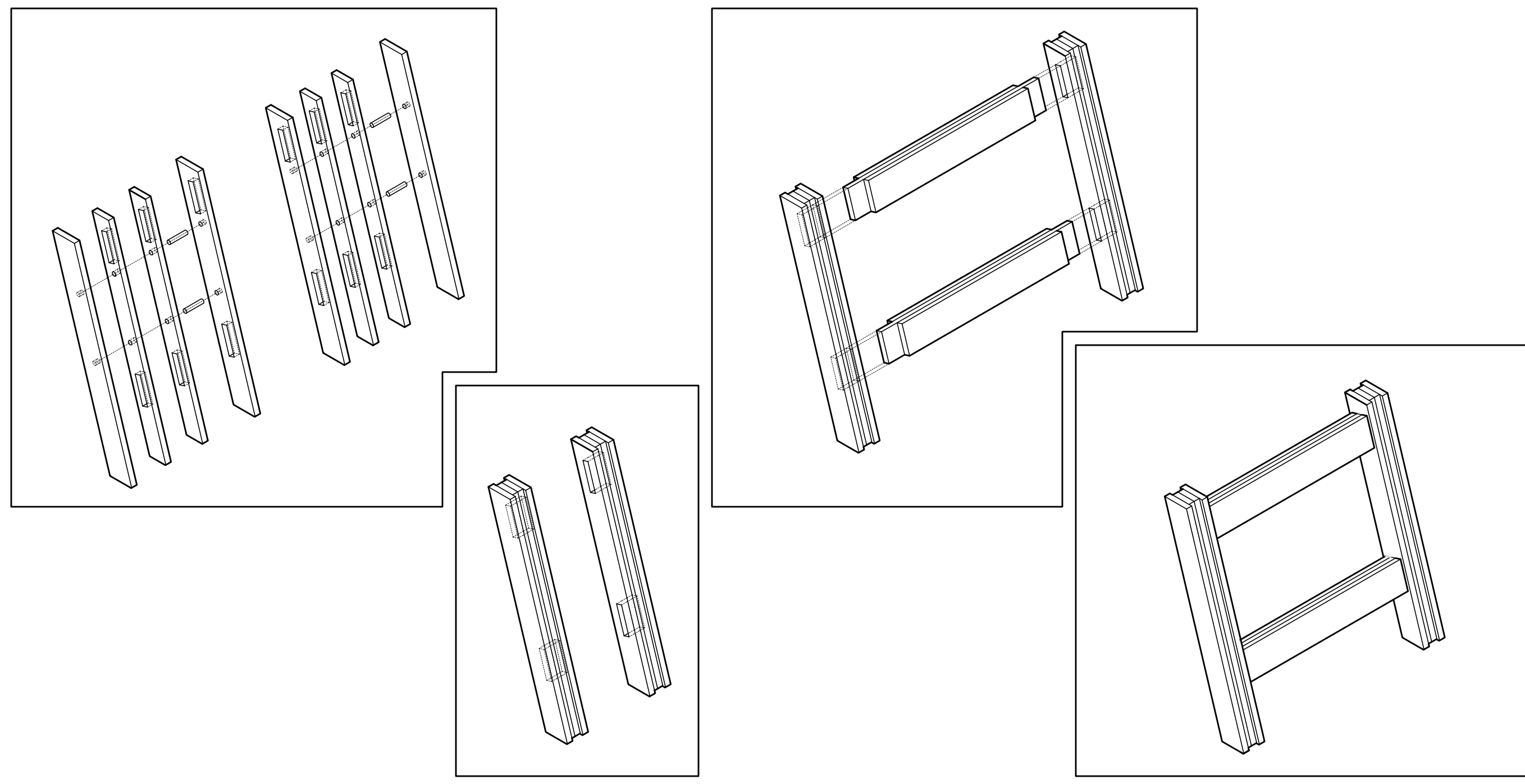

05.00:bottom shelf assembly 1X

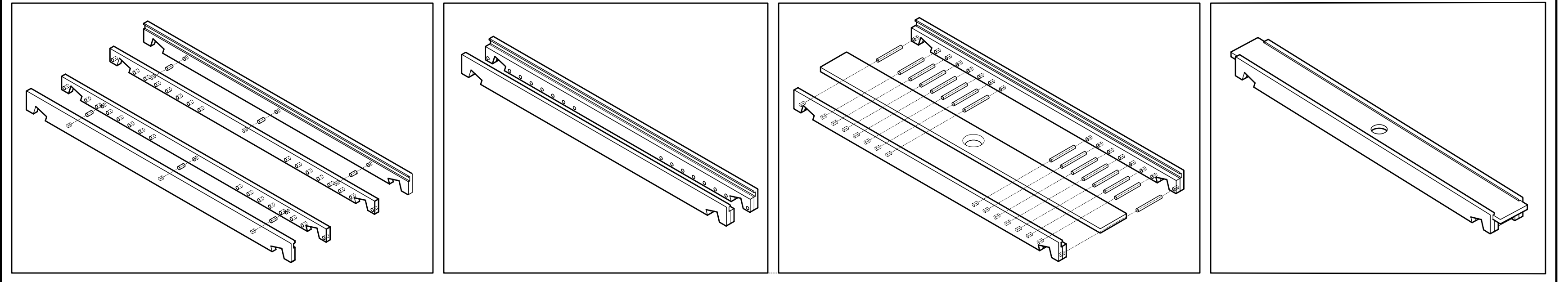

06.00 top rail assembly 2X

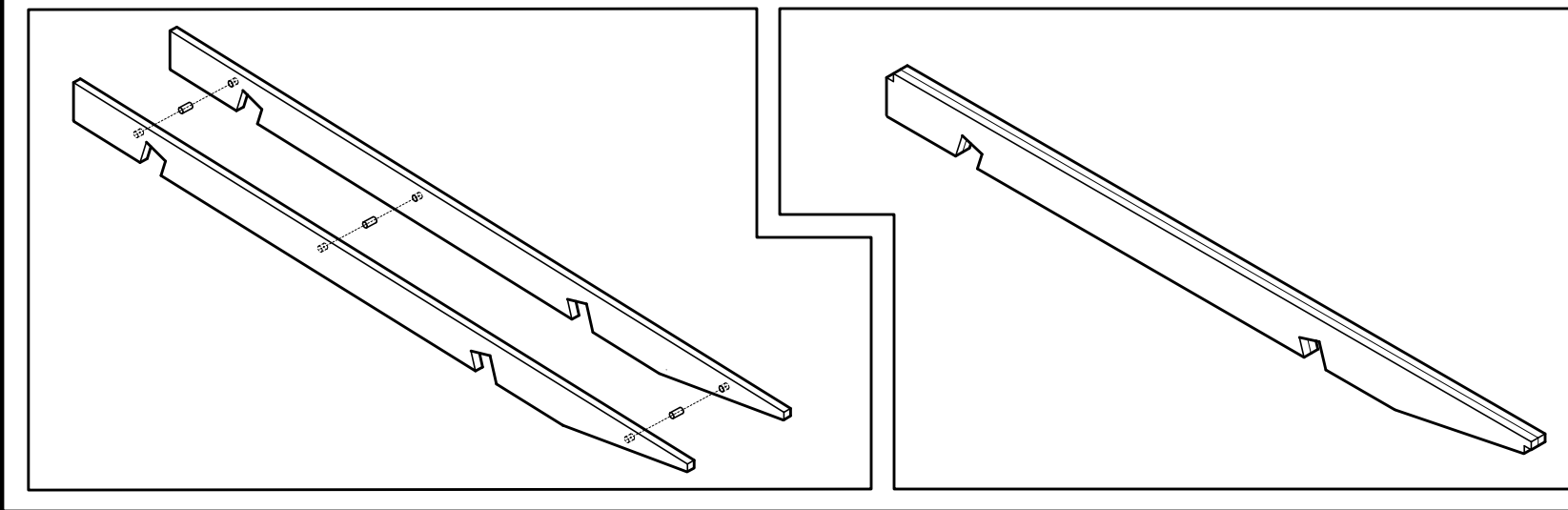

07.00 top assembly 1X

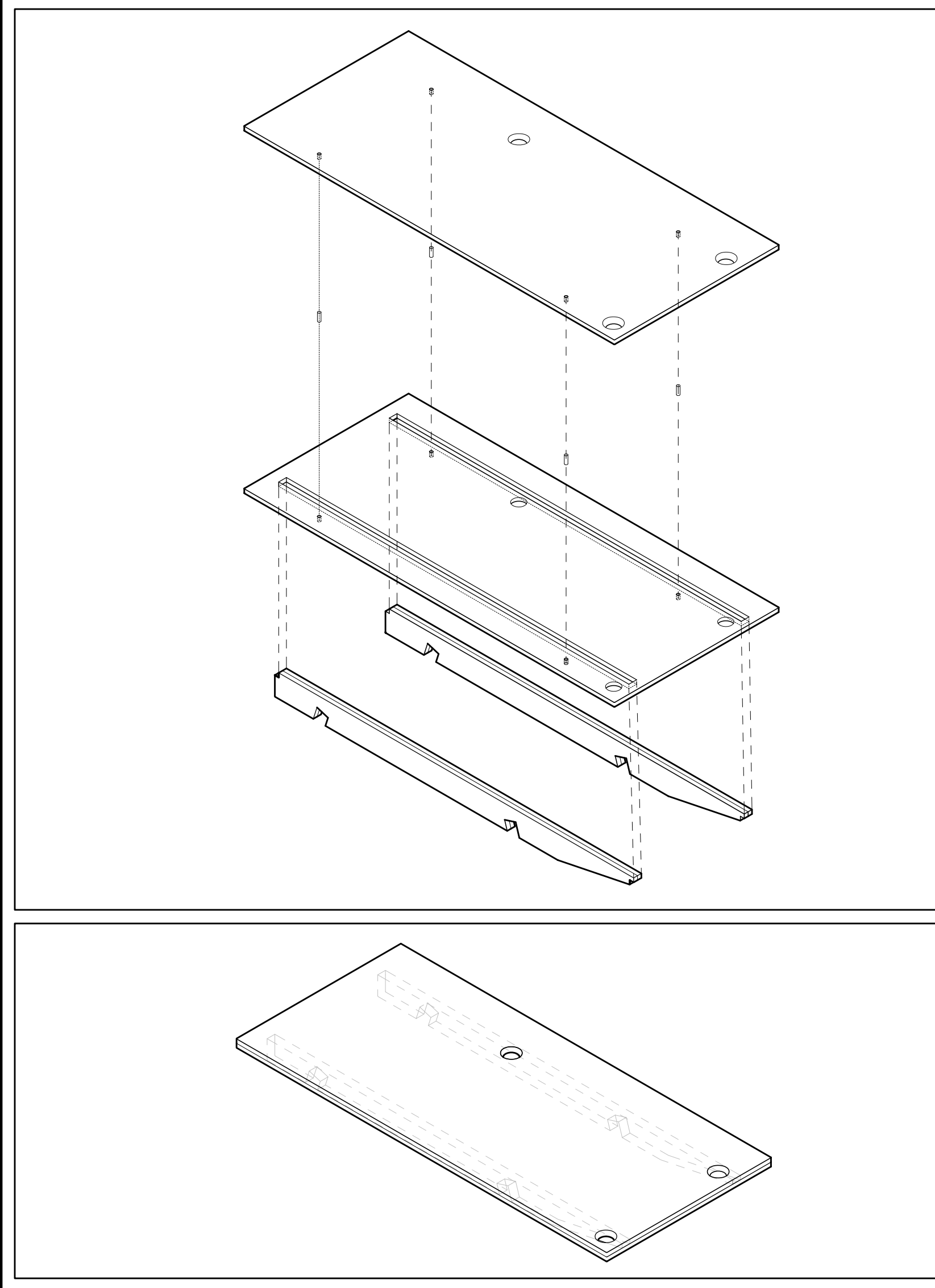

08.00 workbench assembly

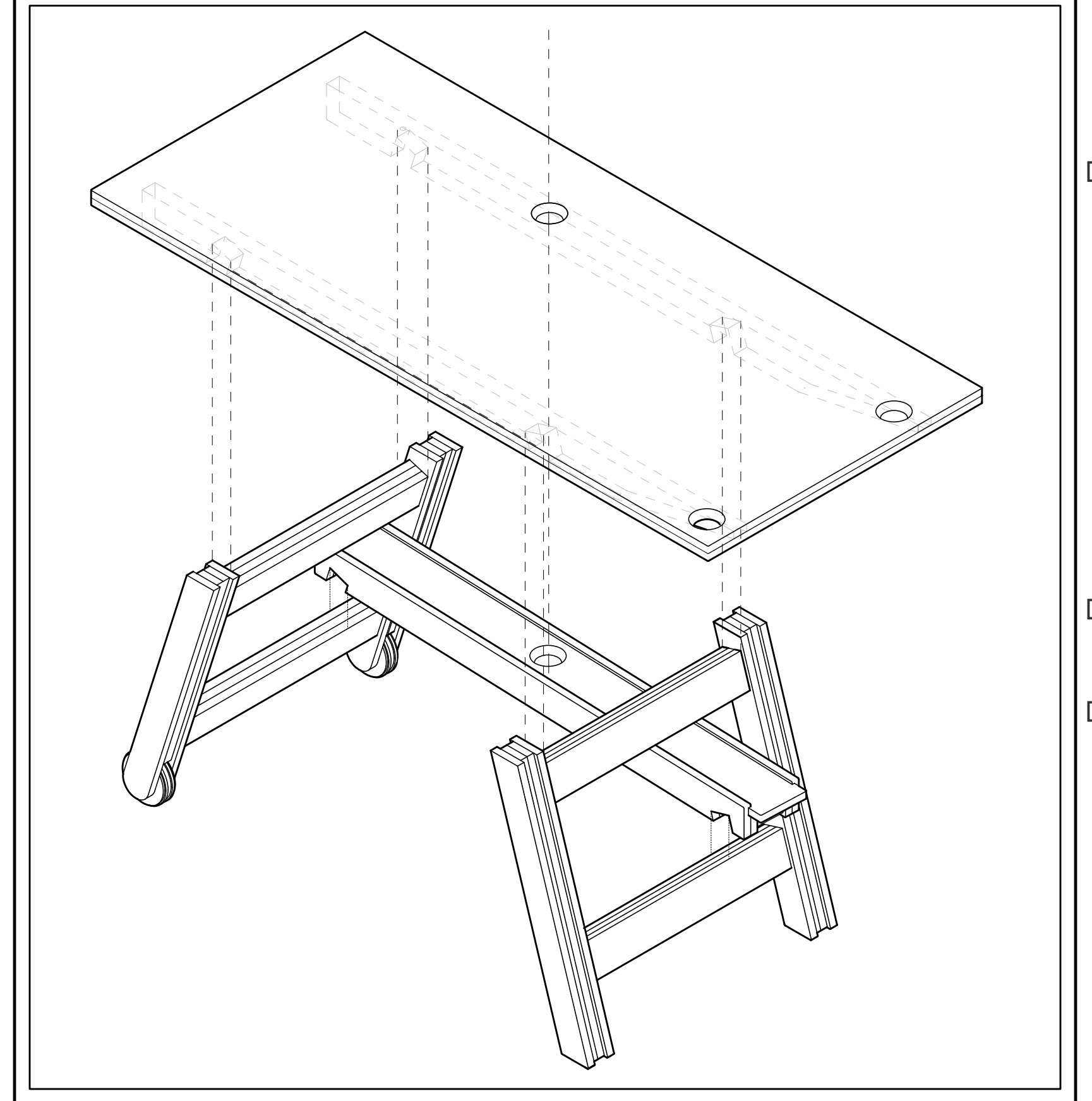

assembled workbench

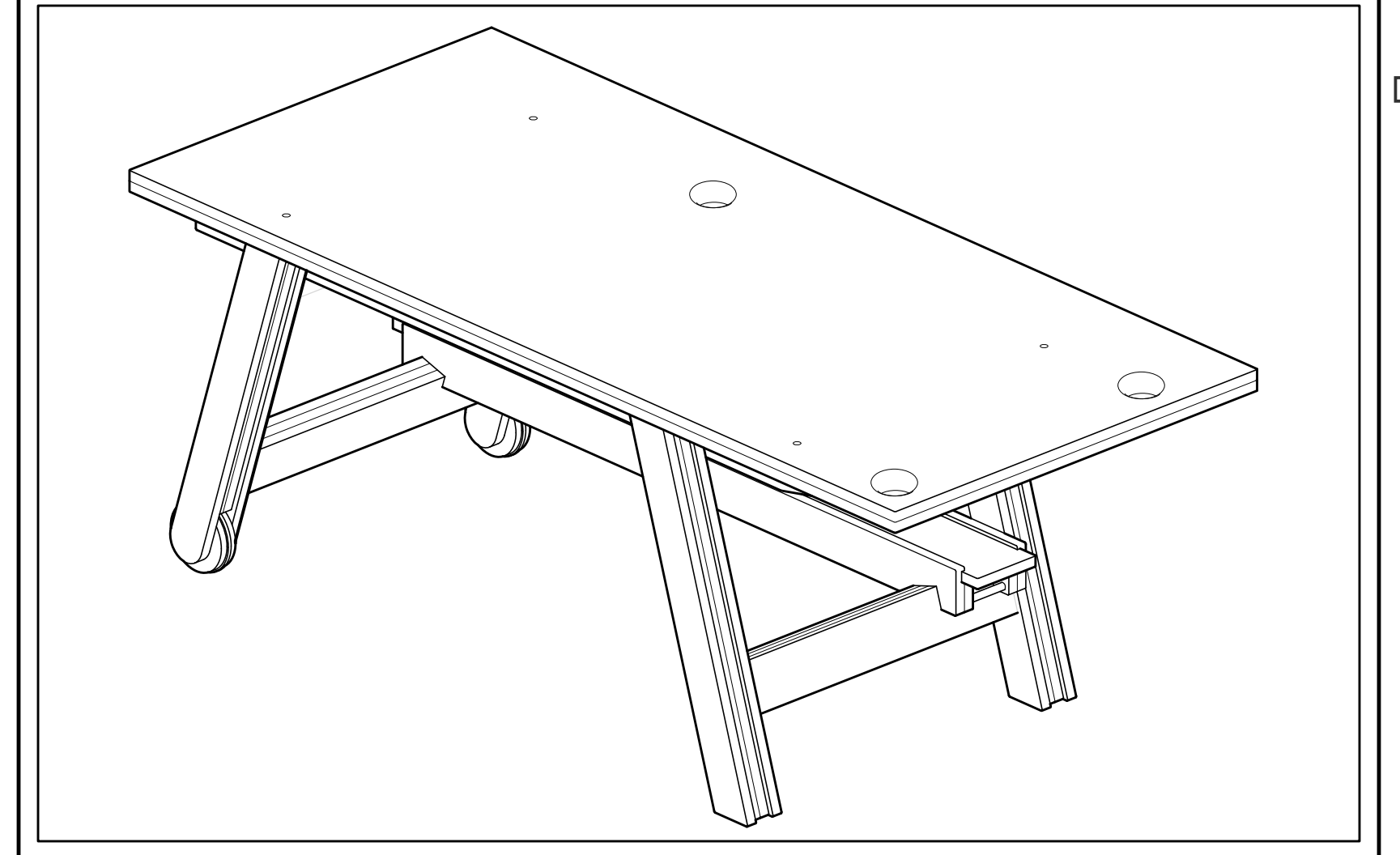

nomadic workbench

assembly instructions

moravian workbench Old Salem NC

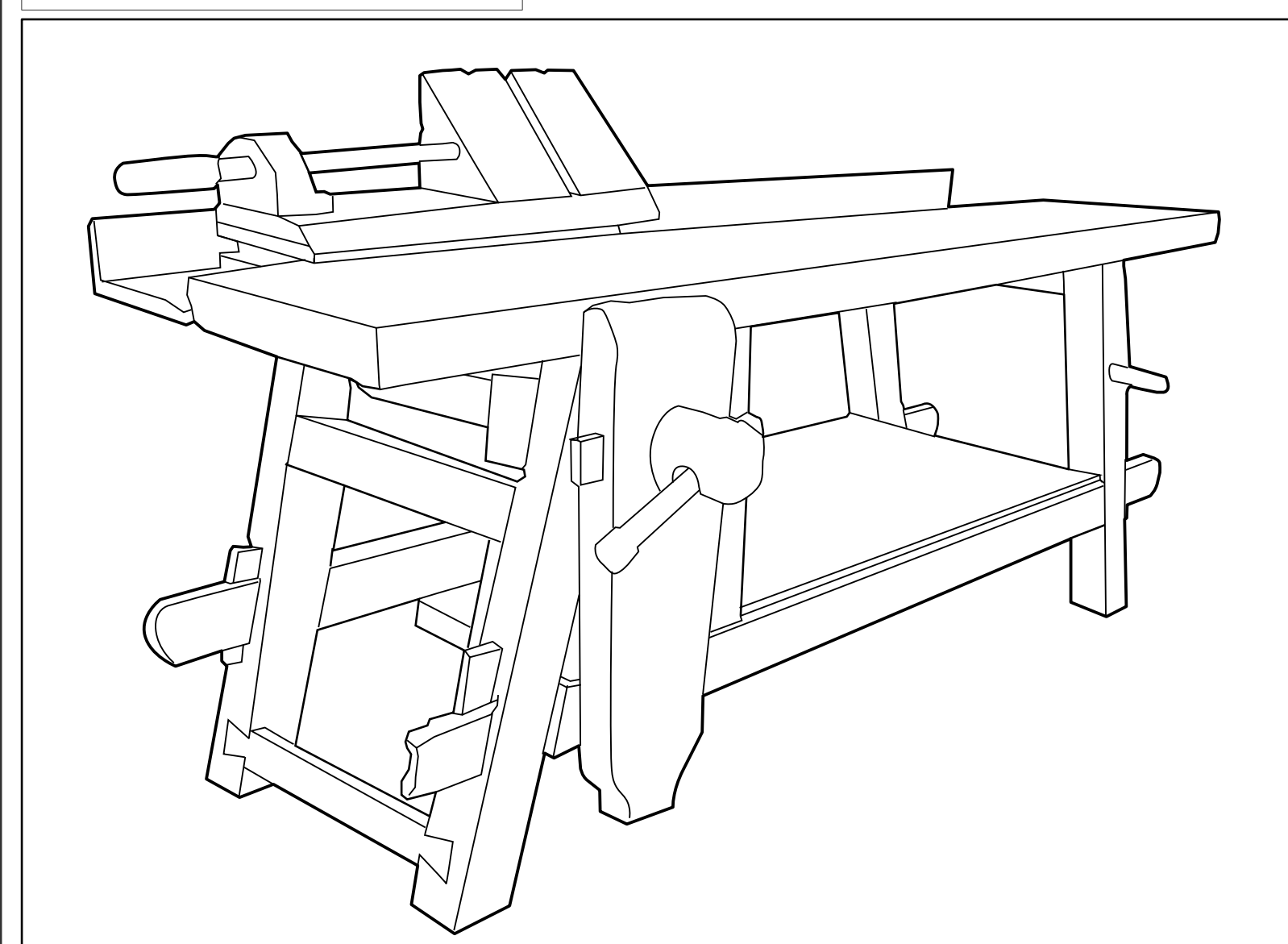

CNC fabrication

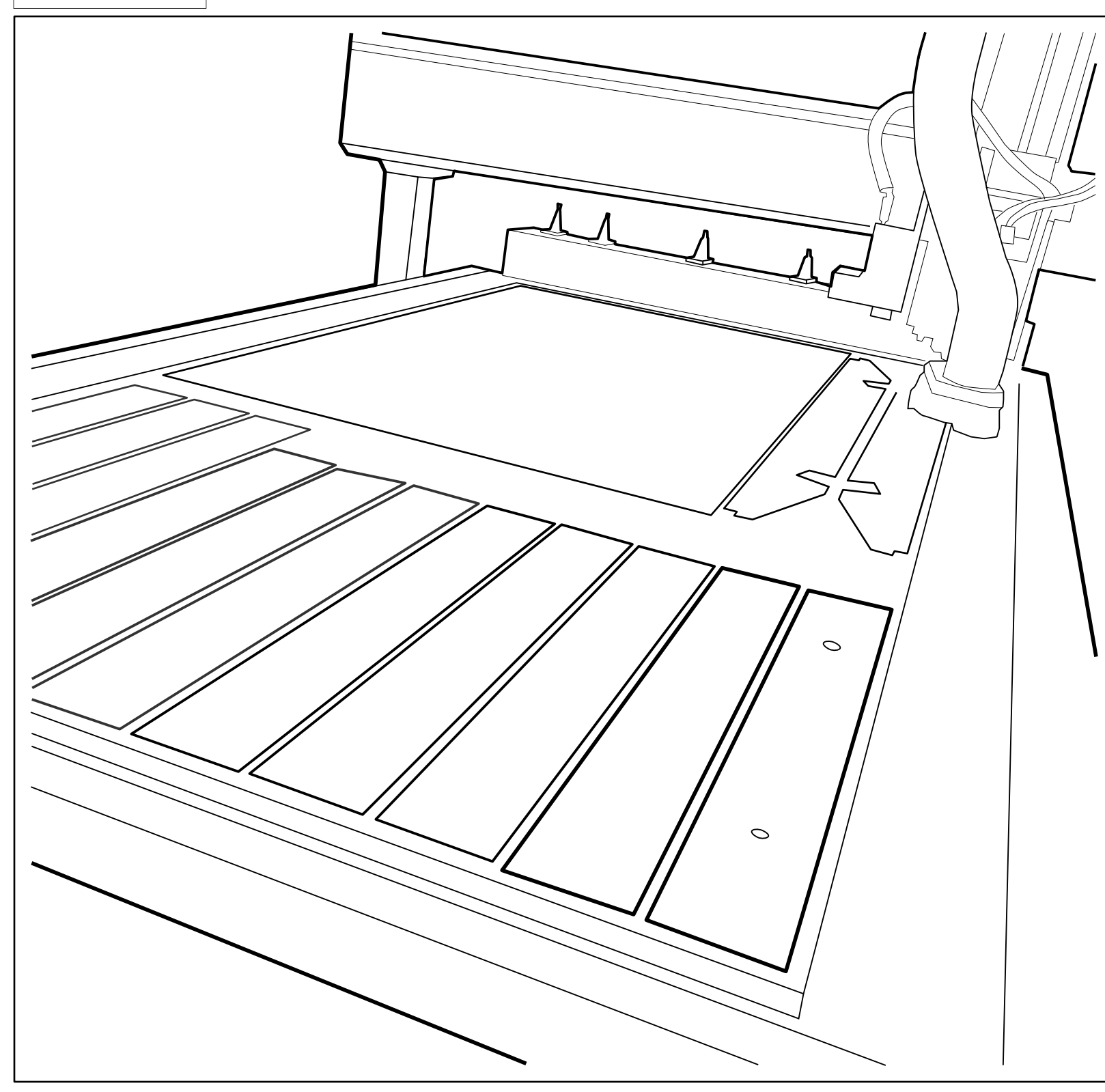

Nomadic Desk with no glue or fasteners (Hennessey and Papanek)

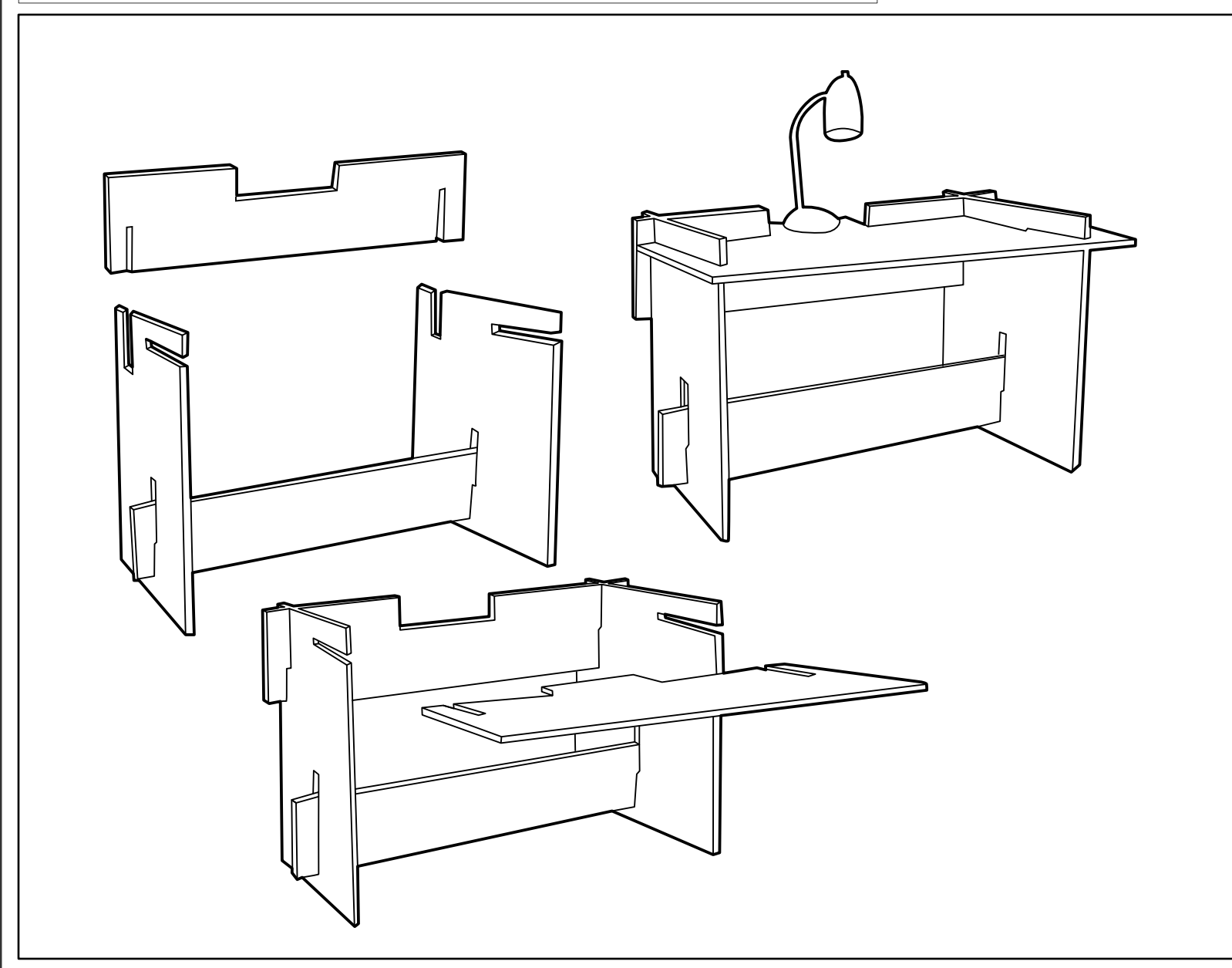

fabrication process post CNC = glue and clamp, sand, hand rubbed finish

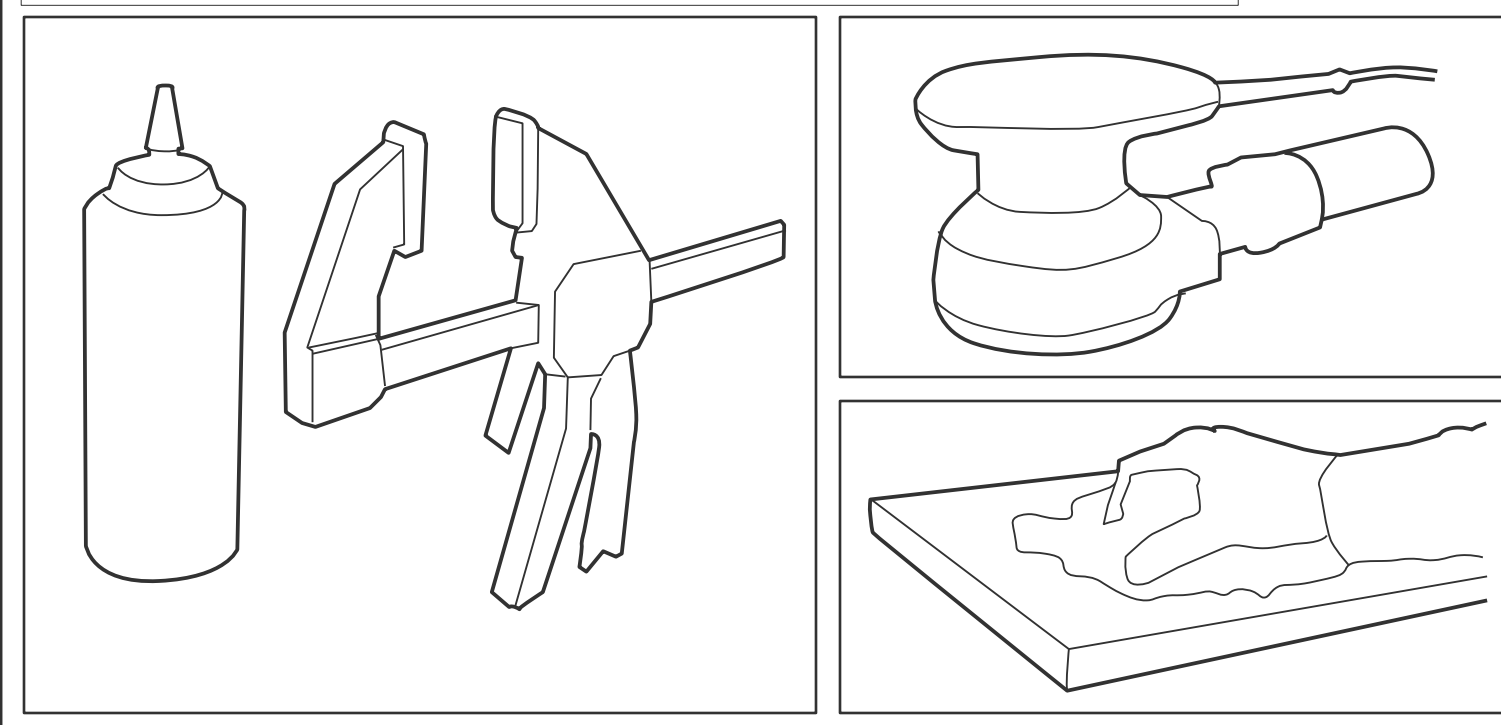

final production full scale front view



final production full scale



proportion study sketch

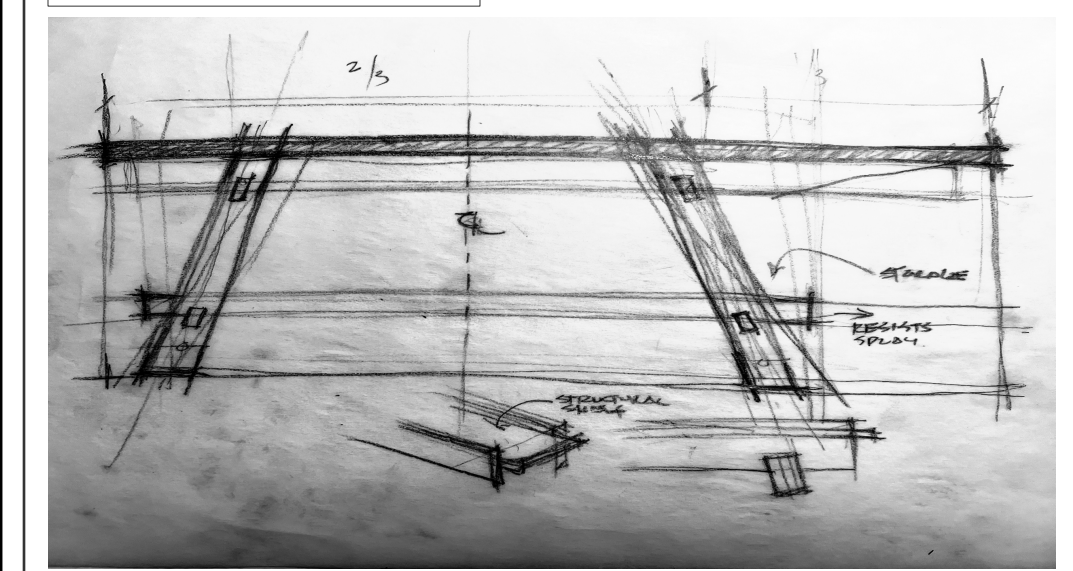

1/3 scale prototype to test structural integrity



1/3 scale prototype disassembled to test mobility



3-d development sketch

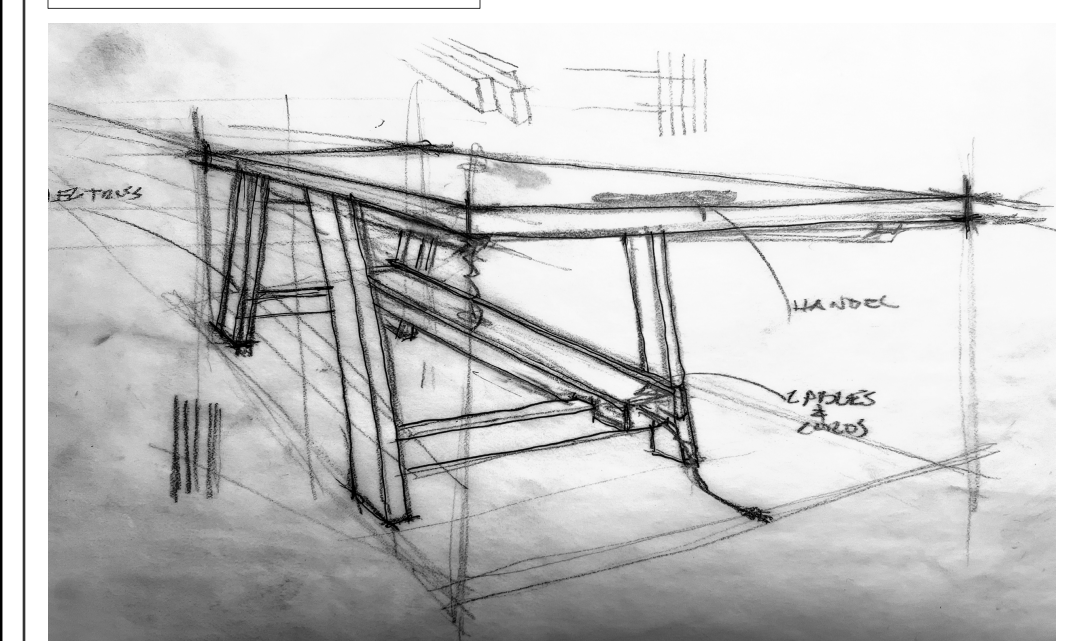

1/3 scale prototype



truss and handle detail full scale



final production wheel detail

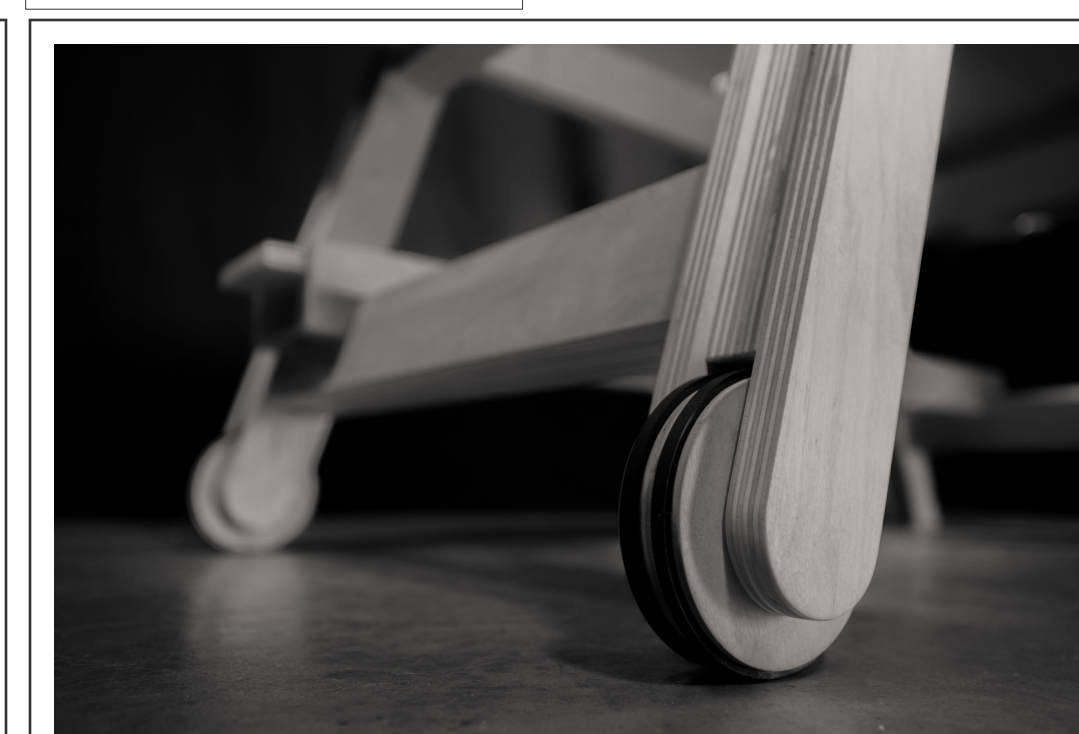

final production top detail



nomadic workbench

process and outcome